



# **Huawei AirEngine 5773- 23WP&AirEngine 5773-23W Access Points Datasheet**

# Product Overview

Huawei AirEngine 5773-23WP&AirEngine 5773-23W are wall plate access points (APs) in compliance with Wi-Fi 7 (802.11be). They can simultaneously provide services on 2.4 GHz (2x2 MIMO) and 5 GHz (2x2 MIMO) frequency bands. Designed with a total of 4 spatial streams, the APs deliver a data rate of up to 3.57 Gbps. The APs draw on Wi-Fi 7 innovations to redefine wireless user experience. These strengths make AirEngine 5773-23WP&AirEngine 5773-23W ideal for indoor coverage scenarios such as dormitories and hotels.



AirEngine 5773-23WP



AirEngine 5773-23W

- Provide services simultaneously on both the 2.4 GHz (2x2 MIMO) and 5 GHz (2x2 MIMO) frequency bands, at a data rate of up to 689 Mbps at 2.4 GHz and 2.88 Gbps at 5 GHz, 3.57 Gbps for the entire AP.
- Built-in smart antennas that automatically adjust the coverage direction and signal strength based on the intelligent switchover algorithm. Such capability enables the AP to flexibly adapt to the application environment changes, providing accurate and stable coverage as STAs move.
- Support Bluetooth serial port-based O&M through built-in Bluetooth and CloudCampus APP.
- Support Fit AP, Fat AP and cloud-managed AP modes, easily managing the AP and its services on Huawei cloud management platform and reducing network O&M costs.

## NOTE

- The feature description and specification are based on the version of V600R25C00.

# Feature Descriptions

## Wi-Fi 7 (802.11be) standard

Wi-Fi 7 (802.11be) is the Wi-Fi standard, also known as IEEE 802.11be or extremely high throughput (EHT). Based on Wi-Fi 6, Wi-Fi 7 introduces technologies such as 4096-quadrature amplitude modulation (QAM), multi-resource unit (MRU), multi-link operation (MLO), enhanced multi-user multiple-input multiple-output (MU-MIMO). Drawing on these cutting-edge technologies, Wi-Fi 7 delivers a higher data transmission rate and lower latency than Wi-Fi 6.

## New Features in Wi-Fi 7

Wi-Fi 7 aims to increase the WLAN throughput and provide low-latency access assurance. To achieve this goal, the Wi-Fi 7 standard defines modifications to both the physical layer (PHY) and MAC layer. Compared with Wi-Fi 6, Wi-Fi 7 brings the following technical innovations:

### Multi-RU

In Wi-Fi 6, each user can send or receive frames only on the RUs allocated to them, which greatly limits the flexibility of spectrum resource scheduling. To resolve this problem and further improve spectrum efficiency, Wi-Fi 7 defines a mechanism for allocating multiple RUs to a single user. To balance the implementation complexity and spectrum utilization, the standard specifications impose certain restrictions on RU combination. That is, small RUs (containing fewer than 242 tones) can be combined only with small RUs, and large RUs (containing greater than or equal to 242 tones) can be combined only with large RUs. Small RUs and large RUs can be combined together.

### Higher-Order 4096-QAM

The highest order modulation supported by Wi-Fi 6 is 1024-QAM, which allows each modulation symbol to carry up to 10 bits. To further improve the rate, Wi-Fi 7 introduces 4096-QAM so that each modulation symbol can carry 12 bits. With the same coding, 4096-QAM in Wi-Fi 7 can achieve a 20% rate increase compared with 1024-QAM in Wi-Fi 6.

### Multi-Link Mechanism

To efficiently utilize all available spectrum resources, the industry is in urgent need to introduce new spectrum management, coordination, and transmission mechanisms on the 2.4 GHz, 5 GHz, and 6 GHz frequency bands. The TGbe defines multi-link aggregation technologies, including the MAC architecture of enhanced multi-link aggregation, multi-link channel access, and multi-link transmission.

There are two modes as for MLO:

- High-concurrency mode, multiple links send different data to improve bandwidth.
- High-reliability mode, multiple links send the same data, improving reliability.

### Wi-Fi CSI Sensing

Wi-Fi CSI sensing is a cutting-edge technology for implementing sensing by using channel state information (Channel State Information, CSI) generated during radio signal propagation. Based on the Wi-Fi 7 standard, Huawei innovatively introduces Wi-Fi CSI to sense the presence of personnel, so that Wi-Fi signals can be sensed wherever they are. Compared with cameras, it protects user privacy and applies to scenarios such as energy saving, health care, and smart security.

### Leader AP

The leader AP integrates some WLAN AC functions and can be used to manage Fit APs in small- and medium-sized enterprises and stores, implementing WLAN AC-free access not requiring licenses and saving customer investment.

## Basic Specifications

### Fit AP mode

Item	Description
WLAN features	<p>Compliance with IEEE 802.11be and compatibility with IEEE 802.11a/b/g/n/ac/ax</p> <p>Maximum ratio combining (MRC)</p> <p>Space time block code (STBC)</p> <p>Cyclic Delay Diversity (CDD)/Cyclic Shift Diversity (CSD)</p> <p>Beamforming</p> <p>Multi-user multiple-input multiple-output (MU-MIMO)</p> <p>Orthogonal frequency division multiple access (OFDMA)</p> <p>Preamble puncturing</p> <p>BSS Color</p> <p>TxBF</p> <p>TWT</p> <p>Compliance with 4096-quadrature amplitude modulation (QAM) and compatibility with 1024-QAM, 256-QAM, 64-QAM, 16-QAM, 8-QAM, quadrature phase shift keying (QPSK), and binary phase shift keying (BPSK)</p> <p>Low-density parity-check (LDPC)</p> <p>Frame aggregation, including A-MPDU (Tx/Rx) and A-MSDU (Tx/Rx)</p> <p>802.11 dynamic frequency selection (DFS)</p> <p>Short guard interval (GI) in 20 MHz, 40 MHz, 80 MHz, 160 MHz modes</p> <p>Wi-Fi multimedia (WMM) for priority-based data processing and forwarding</p> <p>WLAN channel management and channel rate adjustment</p>

Item	Description
	<p><b>NOTE</b></p> <p>For detailed management channels, see the <a href="#">Country Codes &amp; Channels Compliance</a>.</p> <p>Automatic channel scanning and interference avoidance</p> <p>Service set identifier (SSID) hiding configuration for each AP, supporting Chinese SSIDs</p> <p>Signal sustain technology (SST)</p> <p>Unscheduled automatic power save delivery (U-APSD)</p> <p>Multi-user call admission control (CAC)</p> <p>Advanced cellular coexistence (ACC), minimizing the impact of interference from cellular networks</p> <p>802.11k and 802.11v smart roaming</p> <p>802.11r fast roaming (<math>\leq 50</math> ms)</p> <p>Terminal location (Single-AP access location)</p>
Network features	<p>Compliance with IEEE 802.3ab</p> <p>Auto-negotiation of the rate and duplex mode, and automatic switchover between Media Dependent Interface (MDI) and Media Dependent Interface Crossover (MDI-X)</p> <p>Compatibility with IEEE 802.1Q</p> <p>SSID-based VLAN assignment</p> <p>Eth-Trunk function</p> <p>Management channel of the AP's uplink port in tagged and untagged modes</p> <p>DHCP client, obtaining IP addresses through DHCP</p> <p>Tunnel data forwarding and direct data forwarding</p> <p>STA isolation in the same VLAN</p> <p>IPv4/IPv6 access control list (ACL)</p> <p>Link Layer Discovery Protocol (LLDP)</p> <p>Service holding when CAPWAP link disconnection in direct data forwarding mode</p> <p>Unified authentication on the AC</p> <p>AC dual-link backup</p> <p>Telemetry, quickly collecting AP status and application experience parameters</p> <p>MESH</p> <p>IPv6 SAVI</p>
QoS features	<p>WMM power save</p> <p>Priority mapping for upstream packets and flow-based mapping for downstream packets</p> <p>Queue mapping and scheduling</p> <p>User-based bandwidth limiting</p> <p>Adaptive bandwidth management (automatic bandwidth adjustment based on the user quantity and radio environment) to improve user experience</p> <p>Application identification and QoS classification to improve voice quality for popular applications, such as Zoom, QQ, and WeChat</p> <p>Airtime scheduling</p> <p>Air interface HQoS scheduling</p>
Security features	<p>Open system authentication</p> <p>WPA2-PSK authentication and encryption (WPA2-Personal)</p> <p>WPA2-802.1X authentication and encryption (WPA2-Enterprise)</p> <p>WPA3-SAE authentication and encryption (WPA3-Personal)</p> <p>WPA3-802.1X authentication and encryption (WPA3-Enterprise)</p> <p>WPA-WPA2 hybrid authentication</p>

Item	Description
	<p>WPA2-WPA3 hybrid authentication</p> <p>WPA/WPA2/WPA2-PPSK authentication and encryption</p> <p>WPA/WPA2/WPA2-DPSK authentication and encryption</p> <p>WAPI authentication and encryption</p> <p>Wireless intrusion detection system (WIDS) and wireless intrusion prevention system (WIPS), including rogue device detection and containment, attack detection and dynamic blacklist, and STA/AP blacklist and whitelist</p> <p>802.1X authentication, MAC address authentication, and Portal authentication</p> <p>DHCP snooping</p> <p>802.11w Protected Management Frames (PMF)</p> <p>CAPWAP DTLS data encryption and decryption</p> <p>URL filtering</p> <p>Secure boot</p>
EAP types	EAP-TLS, EAP-TTLS, EAP-PEAP, EAP-CHAP, EAP-SIM, EAP-AKA, EAP-GTC, EAP-FAST, EAP-PEAP, EAP-MD5, EAP-MSCHAPv2, PEAPv0, PEAPv1
Maintenance features	<p>Unified AP management and maintenance on the AC</p> <p>Automatic AP onboarding, automatic configuration loading, and plug-and-play (PnP)</p> <p>Automatic batch upgrade</p> <p>STelnet using SSHv2</p> <p>SFTP using SSHv2</p> <p>Remote wireless O&amp;M through the Bluetooth serial port</p> <p>System status alarm</p> <p>Unified AP management on WebMaster</p>
Sensing	Wi-Fi CSI Sensing

## Fat AP mode

Item	Description
WLAN features	<p>Compliance with IEEE 802.11be and compatibility with IEEE 802.11a/b/g/n/ac/ax</p> <p>Maximum ratio combining (MRC)</p> <p>Space time block code (STBC)</p> <p>Cyclic Delay Diversity (CDD)/Cyclic Shift Diversity (CSD)</p> <p>Beamforming</p> <p>Multi-user multiple-input multiple-output (MU-MIMO)</p> <p>Orthogonal frequency division multiple access (OFDMA)</p> <p>Preamble puncturing</p> <p>BSS Color</p> <p>TxBF</p> <p>TWT</p> <p>Compliance with 4096-quadrature amplitude modulation (QAM) and compatibility with 1024-QAM, 256-QAM, 64-QAM, 16-QAM, 8-QAM, quadrature phase shift keying (QPSK), and binary phase shift keying (BPSK)</p> <p>Low-density parity-check (LDPC)</p> <p>Frame aggregation, including A-MPDU (Tx/Rx) and A-MSDU (Tx/Rx)</p> <p>802.11 dynamic frequency selection (DFS)</p>

Item	Description
	<p>Short guard interval (GI) in 20 MHz, 40 MHz, 80 MHz, 160 MHz modes</p> <p>Wi-Fi multimedia (WMM) for priority-based data processing and forwarding</p> <p>WLAN channel management and channel rate adjustment</p> <p><b>NOTE</b></p> <p>For detailed management channels, see the <a href="#">Country Codes &amp; Channels Compliance</a>.</p> <p>Automatic channel scanning and interference avoidance</p> <p>Service set identifier (SSID) hiding configuration for each AP, supporting Chinese SSIDs</p> <p>Signal sustain technology (SST)</p> <p>Unscheduled automatic power save delivery (U-APSD)</p> <p>Advanced cellular coexistence (ACC), minimizing the impact of interference from cellular networks</p> <p>802.11k and 802.11v smart roaming</p> <p>802.11r fast roaming (<math>\leq 50</math> ms)</p>
Network features	<p>Compliance with IEEE 802.3ab</p> <p>Auto-negotiation of the rate and duplex mode, and automatic switchover between Media Dependent Interface (MDI) and Media Dependent Interface Crossover (MDI-X)</p> <p>Compatibility with IEEE 802.1Q</p> <p>SSID-based VLAN assignment</p> <p>DHCP client, obtaining IP addresses through DHCP</p> <p>Tunnel data forwarding and direct data forwarding</p> <p>STA isolation in the same VLAN</p> <p>IPv4 access control list (ACL)</p> <p>Link Layer Discovery Protocol (LLDP)</p> <p>Leader AP</p> <p>NAT</p>
QoS features	<p>WMM power save</p> <p>Priority mapping for upstream packets and flow-based mapping for downstream packets</p> <p>Queue mapping and scheduling</p> <p>User-based bandwidth limiting</p> <p>Airtime scheduling</p>
Security features	<p>Open system authentication</p> <p>WPA2-PSK authentication and encryption (WPA2-Personal)</p> <p>WPA3-SAE authentication and encryption (WPA3-Personal)</p> <p>WPA-WPA2 hybrid authentication</p> <p>WPA2-WPA3 hybrid authentication</p> <p>MAC address authentication, and Portal authentication</p> <p>DHCP snooping</p> <p>802.11w Protected Management Frames (PMF)</p> <p>URL filtering</p> <p>Secure boot</p>
EAP types	EAP-TLS, EAP-TTLS, EAP-PEAP, EAP-CHAP, EAP-SIM, EAP-AKA, EAP-GTC, EAP-FAST, EAP-PEAP, EAP-MD5, EAP-MSCHAPv2, PEAPv0, PEAPv1
Maintenance features	<p>STelnet using SSHv2</p> <p>SFTP using SSHv2</p> <p>Remote wireless O&amp;M through the Bluetooth serial port</p>

Item	Description
	System status alarm

## Cloud-Managed AP mode

Item	Description
WLAN features	<p>Compliance with IEEE 802.11be and compatibility with IEEE 802.11a/b/g/n/ac/ax</p> <p>Maximum ratio combining (MRC)</p> <p>Space time block code (STBC)</p> <p>Cyclic Delay Diversity (CDD)/Cyclic Shift Diversity (CSD)</p> <p>Beamforming</p> <p>Multi-user multiple-input multiple-output (MU-MIMO)</p> <p>Orthogonal frequency division multiple access (OFDMA)</p> <p>Preamble puncturing</p> <p>BSS Color</p> <p>TxBF</p> <p>TWT</p> <p>Compliance with 4096-quadrature amplitude modulation (QAM) and compatibility with 1024-QAM, 256-QAM, 64-QAM, 16-QAM, 8-QAM, quadrature phase shift keying (QPSK), and binary phase shift keying (BPSK)</p> <p>Low-density parity-check (LDPC)</p> <p>Frame aggregation, including A-MPDU (Tx/Rx) and A-MSDU (Tx/Rx)</p> <p>802.11 dynamic frequency selection (DFS)</p> <p>Short guard interval (GI) in 20 MHz, 40 MHz, 80 MHz, 160 MHz modes</p> <p>Wi-Fi multimedia (WMM) for priority-based data processing and forwarding</p> <p>WLAN channel management and channel rate adjustment</p> <p><b>NOTE</b></p> <p>For detailed management channels, see the <a href="#">Country Codes &amp; Channels Compliance</a>.</p> <p>Automatic channel scanning and interference avoidance</p> <p>Service set identifier (SSID) hiding configuration for each AP, supporting Chinese SSIDs</p> <p>Signal sustain technology (SST)</p> <p>Unscheduled automatic power save delivery (U-APSD)</p> <p>Automatic AP Online by NCE-Campus</p> <p>Multi-user call admission control (CAC)</p> <p>Advanced cellular coexistence (ACC), minimizing the impact of interference from cellular networks</p> <p>802.11k and 802.11v smart roaming</p> <p>802.11r fast roaming (<math>\leq 50</math> ms)</p>
Network features	<p>Compliance with IEEE 802.3ab</p> <p>Auto-negotiation of the rate and duplex mode, and automatic switchover between Media Dependent Interface (MDI) and Media Dependent Interface Crossover (MDI-X)</p> <p>Compatibility with IEEE 802.1Q</p> <p>SSID-based VLAN assignment</p> <p>DHCP client, obtaining IP addresses through DHCP</p> <p>STA isolation in the same VLAN</p> <p>IPv4/IPv6 access control list (ACL)</p> <p>Link Layer Discovery Protocol (LLDP)</p>

Item	Description
	Service holdover when the link to NCE-Campus is disconnected Unified authentication on the cloud management platform Network address translation (NAT) Telemetry, quickly collecting AP status and application experience parameters MESH Tunnel-AC IPv6 SAVI
QoS features	WMM power save Priority mapping for upstream packets and flow-based mapping for downstream packets Queue mapping and scheduling User-based bandwidth limiting Adaptive bandwidth management (automatic bandwidth adjustment based on the user quantity and radio environment) to improve user experience Application identification and QoS classification to improve voice quality for popular applications, such as Zoom, QQ, and WeChat Airtime scheduling Air interface HQoS scheduling
Security features	Open system authentication WPA2-PSK authentication and encryption (WPA2-Personal) WPA2-802.1X authentication and encryption (WPA2-Enterprise) WPA3-SAE authentication and encryption (WPA3-Personal) WPA3-802.1X authentication and encryption (WPA3-Enterprise) WPA-WPA2 hybrid authentication WPA2-WPA3 hybrid authentication WPA/WPA2/WPA2-PPSK authentication and encryption WPA/WPA2/WPA2-DPSK authentication and encryption 802.1X authentication, MAC address authentication, and Portal authentication Wireless intrusion detection system (WIDS) and wireless intrusion prevention system (WIPS), including rogue device detection and containment, attack detection and dynamic blacklist, and STA/AP blacklist and whitelist DHCP snooping 802.11w Protected Management Frames (PMF) CAPWAP DTLS data encryption and decryption Secure boot
EAP types	EAP-TLS, EAP-TTLS, EAP-PEAP, EAP-CHAP, EAP-SIM, EAP-AKA, EAP-GTC, EAP-FAST, EAP-PEAP, EAP-MD5, EAP-MSCHAPv2, PEAPv0, PEAPv1
Maintenance features	Unified AP management and maintenance on the cloud management platform Automatic AP onboarding, automatic configuration loading, and PnP Batch upgrade STelnet using SSHv2 SFTP using SSHv2 Remote wireless O&M through the Bluetooth serial port Real-time user configuration monitoring and fast fault locating using the NMS System status alarm Network Time Protocol (NTP)

Item	Description
Sensing	Wi-Fi CSI Sensing

## Technical Specifications

Item		AirEngine 5773-23WP	AirEngine 5773-23W
Technical specifications	Dimensions (H x W x D)	185 mm x 86 mm x 45 mm	175 mm x 86 mm x 45 mm
	Weight	0.41 kg	
	Port type	1 x 100M/1000M/2.5GE (RJ-45) 5 x 10M/100M/1GE (RJ-45) 1 x USB port <b>NOTE</b> <ul style="list-style-type: none"> <li>The 2.5GE (RJ-45) supports PoE input.</li> <li>Two GE (RJ-45) (GE3 and GE4) support PoE output(in compliance with 802.3af).</li> </ul>	1 x 100M/1000M/2.5GE (RJ-45) 4 x 10M/100M/1GE (RJ-45) 2 x RJ45 Pass through 1 x USB port <b>NOTE</b> The 2.5GE(RJ-45) supports PoE input.
	IoT	<ul style="list-style-type: none"> <li>Built-in multi-protocol IoT interfaces, flexibly supporting BLE, ZigBee, HomeKit, and Thread*</li> <li>USB port extension external IoT (Supports protocols such as ZigBee, RFID, and UWB)</li> </ul> <b>NOTE</b> Features marked with asterisks (*) can be implemented through software upgrade.	<ul style="list-style-type: none"> <li>USB port extension external IoT (Supports protocols such as ZigBee, RFID, and UWB)</li> </ul>
	LED indicator	Indicates the power-on, startup, running, alarm, and fault states of the system.	
Power specifications	Power input	<ul style="list-style-type: none"> <li>DC: 43.2 V to 57.6 V</li> <li>PoE power supply: in compliance with 802.3bt/at/af</li> </ul> <b>NOTE</b> 802.3at/af power supply restrictions are detailed in the <a href="#">Info-Finder</a> .	<ul style="list-style-type: none"> <li>DC: 12V±10%</li> <li>PoE power supply: in compliance with 802.3at/af</li> </ul> <b>NOTE</b> 802.3af power supply restrictions are detailed in the <a href="#">Info-Finder</a> .
	Maximum power consumption	14.7 W (excluding USB and PoE OUT) <b>NOTE</b> <ul style="list-style-type: none"> <li>It is 15.9 W for AirEngine 5773-23WP (50087135).</li> <li>The actual maximum power consumption depends on local laws and regulations.</li> </ul>	13.2W (excluding USB)
Environmental specifications	Operating temperature	0°C to +40°C	
	Storage temperature	-40°C to +70°C	
	Operating humidity	5% to 95% (non-condensing)	
	Altitude	-60 m to +5000 m	

Item		AirEngine 5773-23WP	AirEngine 5773-23W
	Atmospheric pressure	53 kPa to 106 kPa	
Radio specifications	Antenna type	Built-in smart antennas	
	Antenna gain	2.4GHz: 5 dBi 5GHz: 6 dBi <b>NOTE</b> <ul style="list-style-type: none"> <li>The preceding gains are the peak gains of a single antenna.</li> <li>When all WLAN 2.4 GHz or 5 GHz antennas are combined, the equivalent antenna gain is 2 dBi for 2.4 GHz radios or 3 dBi for 5 GHz radios.</li> </ul>	2.4GHz: 5 dBi 5GHz: 5 dBi <b>NOTE</b> <ul style="list-style-type: none"> <li>The preceding gains are the peak gains of a single antenna.</li> <li>When all WLAN 2.4 GHz or 5 GHz antennas are combined, the equivalent antenna gain is 3 dBi for 2.4 GHz radios or 3 dBi for 5 GHz radios.</li> </ul>
	Maximum number of SSIDs for each radio	15	
	Maximum transmit power	2.4 GHz: 23 dBm (combined power) 5 GHz: 23 dBm (combined power) <b>NOTE</b> The actual transmit power depends on local laws and regulations.	
	Frequency bands	2.400 to 2.4835 GHz ISM 5.150 to 5.250 GHz U-NII-1 5.250 to 5.350 GHz U-NII-2A 5.470 to 5.725 GHz U-NII-2C 5.725 to 5.850 GHz U-NII-3/ISM <b>NOTE</b> The available bands and channels are dependent on the configured regulatory domain (country).	

## Standards Compliance

Item	Description		
Safety standards	<ul style="list-style-type: none"> <li>EN 62368-1</li> </ul>	<ul style="list-style-type: none"> <li>IEC 62368-1</li> </ul>	<ul style="list-style-type: none"> <li>GB 4943.1</li> </ul>
Radio standards	<ul style="list-style-type: none"> <li>ETSI EN 300 328</li> </ul>	<ul style="list-style-type: none"> <li>ETSI EN 301 893</li> </ul>	<ul style="list-style-type: none"> <li>AN/NZS 4268</li> </ul>
EMC standards	<ul style="list-style-type: none"> <li>EN 301 489-1</li> <li>EN 301 489-17</li> <li>EN 60601-1-2</li> <li>EN 55032</li> <li>EN 55035</li> </ul>	<ul style="list-style-type: none"> <li>GB 9254</li> <li>GB 17625.2</li> <li>AS/NZS CISPR32</li> <li>CISPR 32</li> <li>CISPR 35</li> </ul>	<ul style="list-style-type: none"> <li>IEC/EN61000-4-2</li> <li>IEC/EN 61000-4-3</li> <li>IEC/EN 61000-4-4</li> <li>IEC/EN 61000-4-5</li> <li>IEC/EN 61000-4-6</li> <li>ICES-003</li> </ul>
IEEE standards	<ul style="list-style-type: none"> <li>IEEE 802.11a/b/g</li> <li>IEEE 802.11n</li> <li>IEEE 802.11ac</li> <li>IEEE 802.11ax</li> </ul>	<ul style="list-style-type: none"> <li>IEEE 802.11h</li> <li>IEEE 802.11d</li> <li>IEEE 802.11e</li> <li>IEEE 802.11k</li> </ul>	<ul style="list-style-type: none"> <li>IEEE 802.11v</li> <li>IEEE 802.11w</li> <li>IEEE 802.11r</li> </ul>

Item	Description	
	<ul style="list-style-type: none"> <li>IEEE 802.11be</li> </ul>	
Security standards	<ul style="list-style-type: none"> <li>802.11i, Wi-Fi Protected Access (WPA), WPA2, WPA2-Enterprise, WPA2-PSK, WPA3, WAPI</li> <li>802.1X</li> <li>Advanced Encryption Standards(AES), Temporal Key Integrity Protocol(TKIP), WEP, Open</li> <li>EAP Type(s)</li> </ul>	
EMF	<ul style="list-style-type: none"> <li>EN 62311</li> </ul>	<ul style="list-style-type: none"> <li>EN 50385</li> </ul>
RoHS	<ul style="list-style-type: none"> <li>Directive 2002/95/EC &amp; 2011/65/EU</li> <li>(EU)2015/863</li> </ul>	
Reach	<ul style="list-style-type: none"> <li>Regulation 1907/2006/EC</li> </ul>	
WEEE	<ul style="list-style-type: none"> <li>Directive 2002/96/EC &amp; 2012/19/EU</li> </ul>	

## Antennas Pattern

### AirEngine 5773-23WP

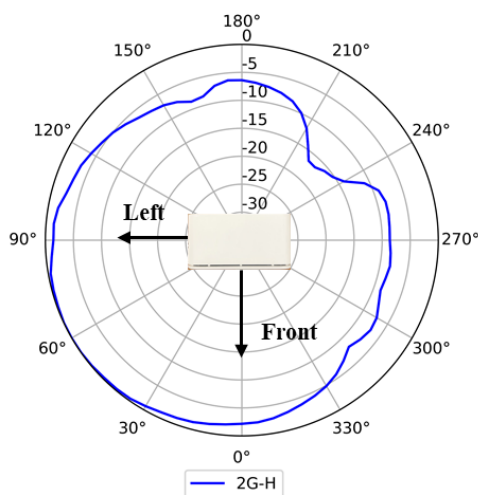

2.4GHz (Horizontal)

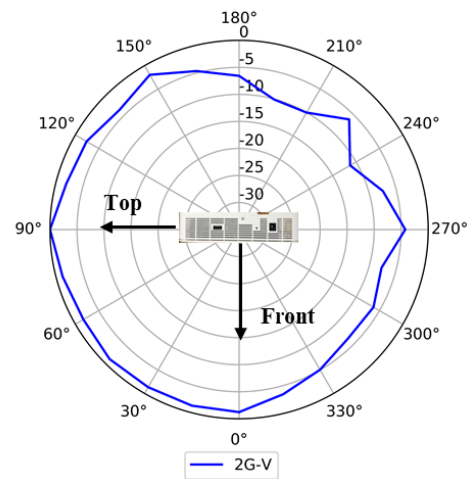

2.4GHz (Vertical)

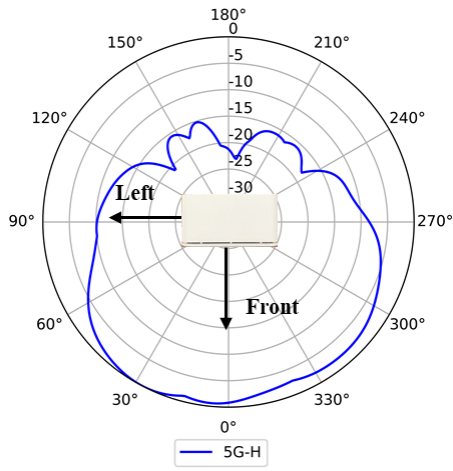

5GHz (Horizontal)

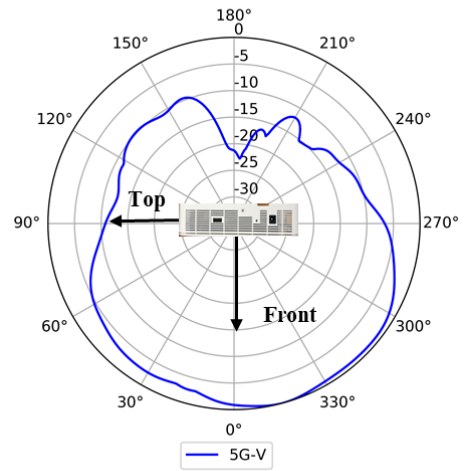

5GHz (Vertical)

### AirEngine 5773-23W

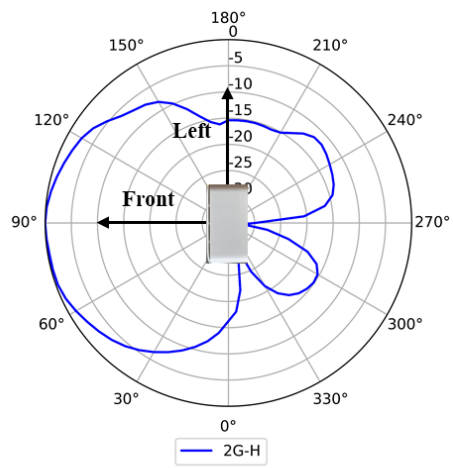

2.4GHz (Horizontal)

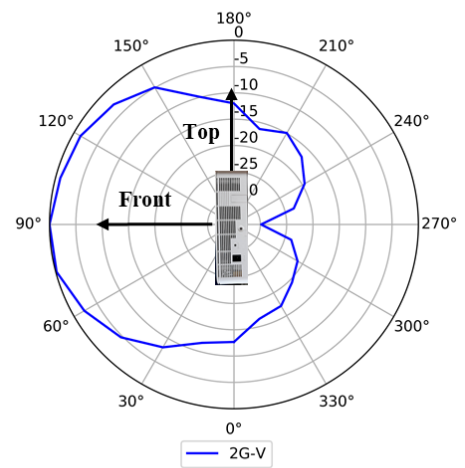

2.4GHz (Vertical)

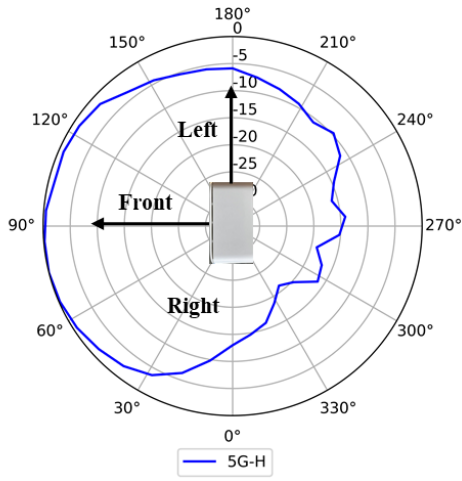

5GHz (Horizontal)

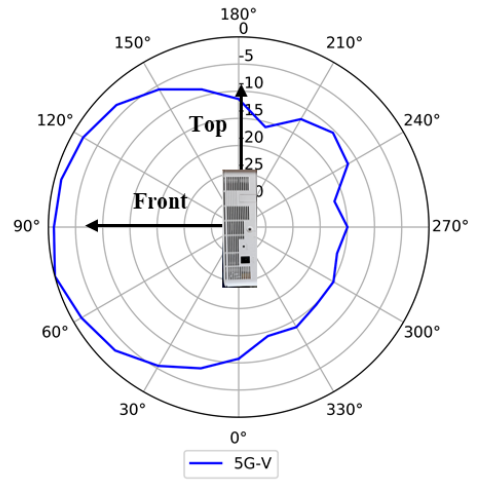

5GHz (Vertical)

**Copyright © Huawei Technologies Co., Ltd. 2025. All rights reserved.**

No part of this document may be reproduced or transmitted in any form or by any means without prior written consent of Huawei Technologies Co., Ltd.

#### **Trademarks and Permissions**



HUAWEI and other Huawei trademarks are trademarks of Huawei Technologies Co., Ltd.

All other trademarks and trade names mentioned in this document are the property of their respective holders.

#### **Notice**

The purchased products, services and features are stipulated by the contract made between Huawei and the customer. All or part of the products, services and features described in this document may not be within the purchase scope or the usage scope. Unless otherwise specified in the contract, all statements, information, and recommendations in this document are provided "AS IS" without warranties, guarantees or representations of any kind, either express or implied.

The information in this document is subject to change without notice. Every effort has been made in the preparation of this document to ensure accuracy of the contents, but all statements, information, and recommendations in this document do not constitute a warranty of any kind, express or implied.

#### **Huawei Technologies Co., Ltd.**

Address: Huawei Industrial Base Bantian, Longgang Shenzhen 518129 People's Republic of China

Website: [www.huawei.com](http://www.huawei.com)